

(No Model.)

3 Sheets—Sheet 1.

E. G. LATTA.

VELOCIPÈDE.

No. 377,204.

Patented Jan. 31, 1888.

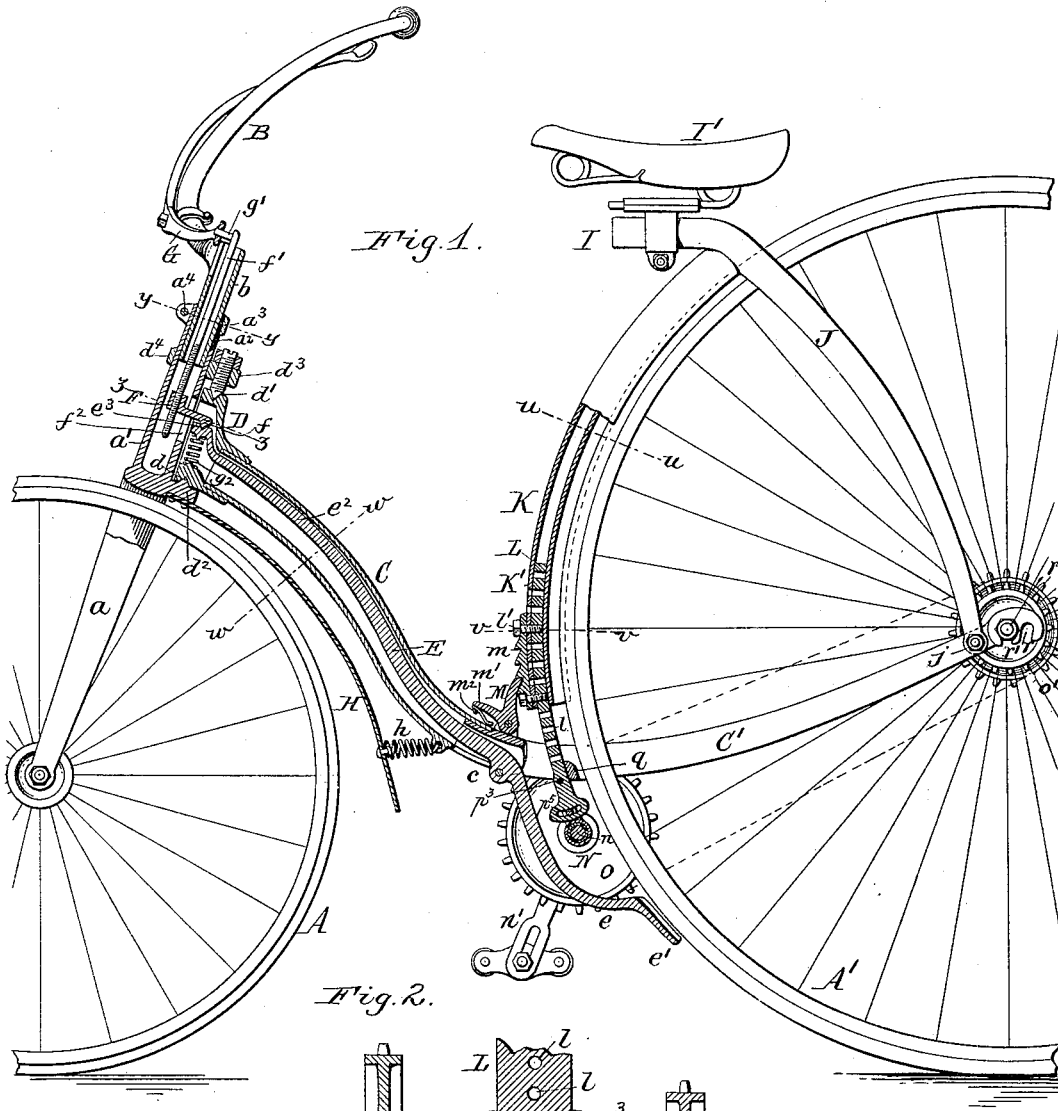
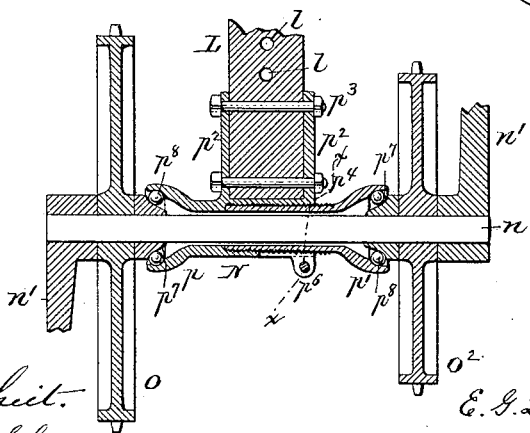

Fig. 2.



witnesses:
Chas. J. Buchheit.
Theodor. L. Popp.

E. G. Latta Inventor.
By Wilhelm Honner.
Attorneys.

(No Model.)

3 Sheets—Sheet 2.

E. G. LATTA.
VELOCIPEDE.

No. 377,204.

Patented Jan. 31, 1888.

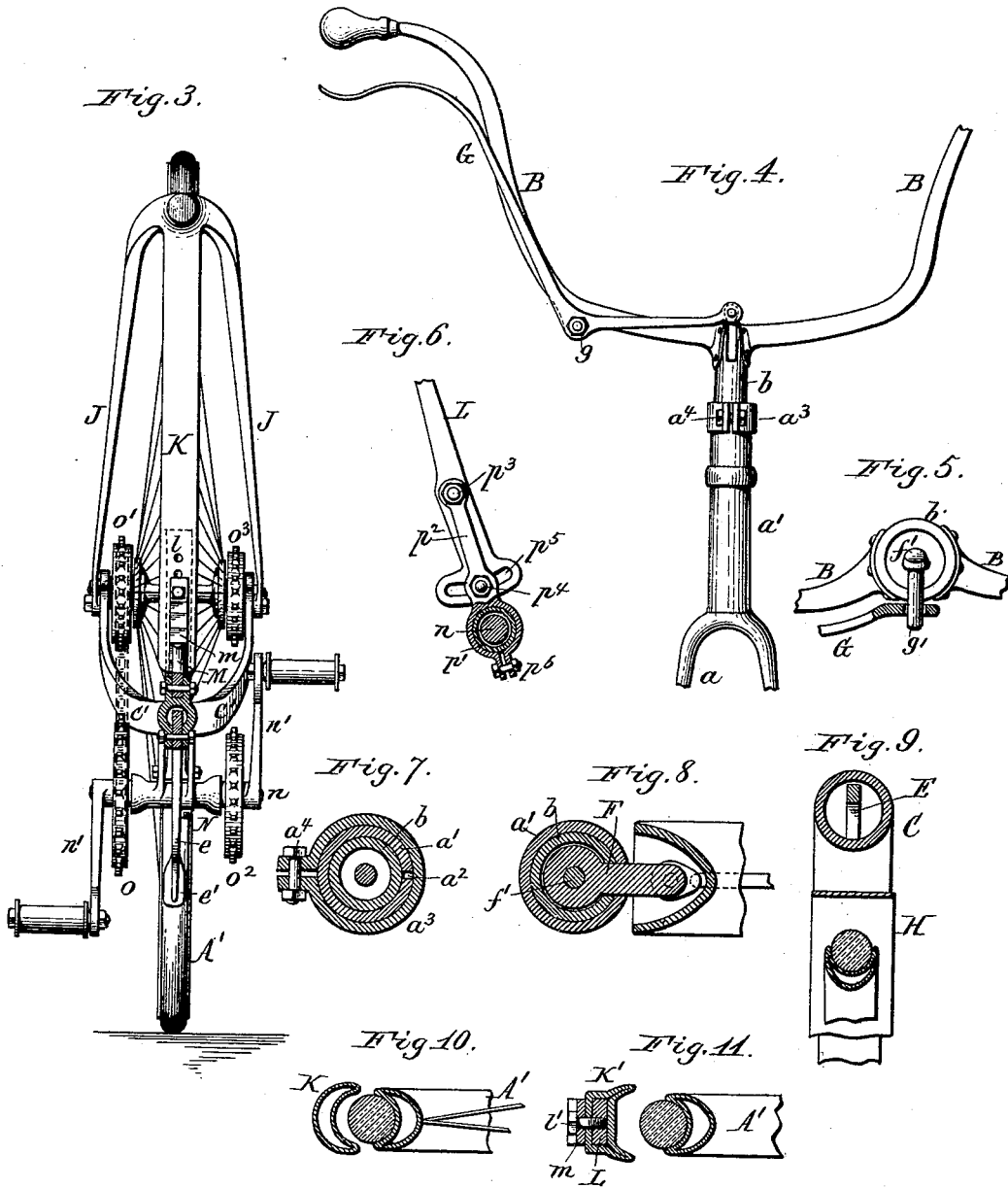

Chas. J. Buchheit.
Theodor. L. Popp. } witnesses.

E. G. Latta Inventor
By Wilhelm Honner
Attorneys.

(No Model.)

3 Sheets—Sheet 3.

E. G. LATTA.
VELOCIPÈDE.

No. 377,204.

Patented Jan. 31, 1888.

Fig. 12.

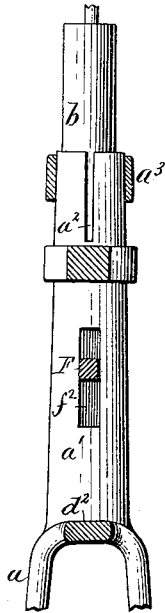

Fig. 13.

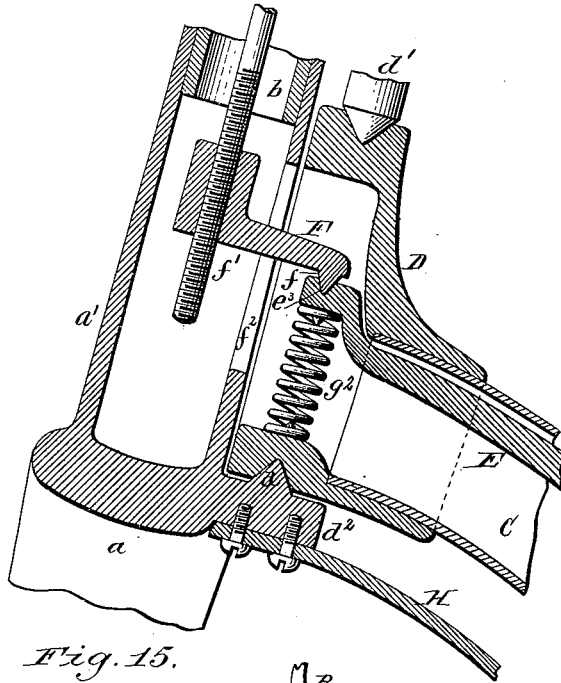

Fig. 14.

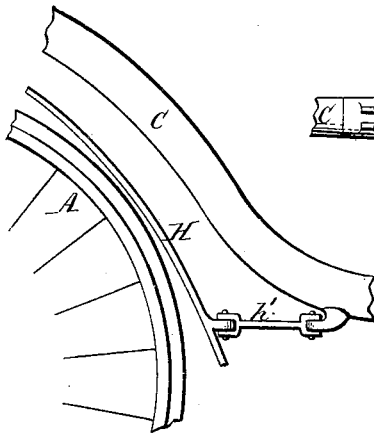

Fig. 15.

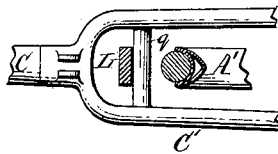
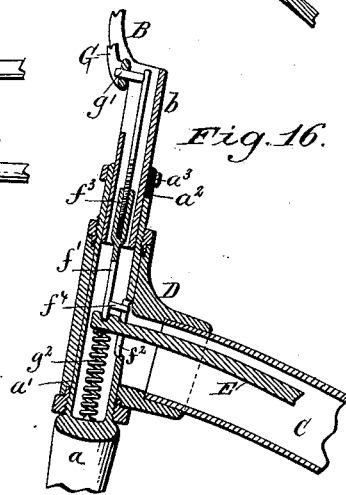

Fig. 16.



Witnesses:
Chas. J. Buchheit.
Theodore L. Popp.

E. G. Latta Inventor.
By Wilhelm Hornum.
Attorneys.

UNITED STATES PATENT OFFICE.

EMMIT G. LATTA, OF FRIENDSHIP, NEW YORK, ASSIGNOR, BY MESNE ASSIGNMENTS, TO THE POPE MANUFACTURING COMPANY, OF PORTLAND, MAINE.

VELOCIPEDE.

SPECIFICATION forming part of Letters Patent No. 377,204, dated January 31, 1888.

Application filed June 10, 1886. Serial No. 204,797. (No model.)

To all whom it may concern:

Be it known that I, EMMIT G. LATTA, of Friendship, in the county of Allegany and State of New York, have invented new and useful Improvements in Velocipedes, of which
5 the following is a specification.

The object of this invention is to render the machine adjustable to riders of different size and to permit the machine to be easily controlled and driven on roads of various grades;
10 also, to provide a simple means for changing the speed of the machine as the condition of the road or rider may require, and to improve the details of construction in several respects.

The invention consists to these ends of the improvements which will be hereinafter fully described, and pointed out in the claims.

In the accompanying drawings, consisting of three sheets, Figure 1 is a sectional side elevation of a bicycle provided with my improvements. Fig. 2 is a cross-section, on an enlarged scale, of the driving-gear. Fig. 3 is a front elevation of the rear portion of the machine. Fig. 4 is a front elevation of the steering-head and connecting parts. Fig. 5 is a top plan view of the steering-head. Fig. 6 is a sectional side elevation of the bearing supporting the driving-gear, the section being taken in line *x x*, Fig. 2. Fig. 7 is a horizontal cross-section of the steering-head, on an enlarged scale, in line *y y*, Fig. 1. Fig. 8 is a similar section in line *z z*, Fig. 1. Fig. 9 is a cross-section in line *w w*, Fig. 1, on an enlarged scale. Figs. 10 and 11 are cross-sections, on an enlarged scale, in lines *u u* and *v v*, Fig. 1, respectively. Fig. 12 is a sectional rear elevation of the steering-head. Fig. 13 is a fragmentary longitudinal sectional elevation of the steering-head on an enlarged scale. Fig. 14 is a side elevation showing a modified construction of the mud-guard. Fig. 15 is a top plan view of the front portion of the rear fork. Fig. 16 is a longitudinal sectional elevation showing a modified construction of the steering-head.
15 20 25 30 35 40 45

Like letters of reference refer to like parts in the several figures.

A represents the front steering-wheel, and
50 A' the rear driving-wheel.

a represents the front fork, provided at its upper end with a hollow steering-post, *a'*, and arranged in a slightly-inclined position, as represented in Fig. 1.

B B represent the handle-bars, bent upwardly and outwardly from the steering-post and secured with their lower ends to a tubular shank, *b*, which extends downwardly from the junction of the handle-bars. The shank *b* fits snugly in the cavity of the steering-post *a'*, so that it can be raised and lowered therein and be held at various heights. For this purpose the upper portion of the steering-post *a'* is provided on its rear side with a longitudinal slit, *a''*, and surrounded by a clamping-band, *a'''*, which is tightened on the front side of the steering-post by a transverse bolt, *a^t*, as represented in Figs. 1 and 7, so that upon loosening the bolt *a^t* the tubular shank *b* can be raised or lowered in the post *a'*, while by tightening the bolt *a^t* the shank *b* is secured in position. By this means the handle-bars are easily raised and lowered.
55 60 65 70

C represents the tubular reach, and C' the rear fork, connected to the rear end of the reach C by a sleeve, *c*.

D represents the steering-head, secured to the front end of the reach C, and provided at its upper and lower ends with sockets, in which engage the lower steering-center, *d*, and the upper steering-center, *d'*. The lower center, *d*, is formed on the upper side of a lug, *d''*, which projects rearwardly from the lower portion of the steering-post *a'*. The upper steering-center, *d'*, consists of a screw which is secured in a lug, *d''*, formed on the rear side of a ring, *d^t*, which surrounds the upper portion of the steering-post *a'*, and is secured thereto by brazing or otherwise.
75 80 85

The steering-head D is open at its front end and its cavity extends over the steering-head to the rear end thereof, which latter is of tubular form and embraces the front end of the reach C.

E represents the brake-lever pivoted to the sleeve *c* at the rear end of the reach and having its rear or short arm, *e*, extending downwardly and provided with a spoon, *e'*, which is adapted to bear against the driving-wheel A'. The long arm *e''* of the brake-lever extends
90 100

tends forwardly and upwardly through the hollow reach C, and terminates in the steering-head D, where it is provided on its upper side with a recess, e^2 , arranged in line with the steering-centers d d' , as represented in Figs. 1 and 13.

F represents a finger arranged with its front portion in the steering-post a' and projecting with its rear end into the steering-head D, where it is provided on its under side with a projection, f , which enters the recess e^2 of the brake-lever. The front portion of the finger F is provided with a screw-threaded boss, in which engages a rod, f' , which is arranged axially in the shank b and steering-post a' and screw-threaded at its lower portion. The finger F plays in a vertical slot, f^2 , formed in the rear side of the steering-post a' .

G represents the brake-lever pivoted to one of the handle-bars and arranged in a backwardly-inclined position corresponding with that of the handle-bars and steering-post, the pivot-bolt g of the brake-lever being arranged at right angles to the inclined handle-bar, so that a backward and upward pull on the handle of the brake-lever G will cause the end of the lower arms of the brake-lever to swing downwardly in a plane parallel with the axis of the steering-post.

g' represents a forwardly-projecting pin formed at the upper end of the rod f' and entering an opening in the lower arm of the brake-lever G, so that the rod f' is moved downwardly by moving the handles of the brake-lever upwardly and backwardly. This movement of the brake-lever G and rod f' causes the finger F to move downwardly, whereby the upper end of the brake-lever E is moved downwardly and the brake-spoon e' is pressed against the driving-wheel A'. Upon releasing the brake-lever G the parts are returned to their former position by a spring, g^2 , interposed between the front end of the brake-lever E and the lower portion of the steering-head D, as represented in Figs. 1 and 13.

The above-described arrangement of the brake-lever E and rod f' dispenses with the employment of the bell-crank lever heretofore used. In order to raise or lower the handle-bars the clamping-bolt a^4 is released and the handle-bars are turned. The shank b and rod f' take part in this turning movement of the handle-bars, and the screw-threads of the rod f' and finger F cause the handle-bars and the shank b to be raised or lowered, according to the direction in which these parts are turned. As the joint between the finger F and the brake-lever E is in line with the steering-centers d d' , the action of the brake-lever is the same when turning the machine as when driving in a straight line.

The front arm of the brake-lever E, finger F, and the parts connected therewith are concealed by the tubular reach C and steering-post a' , whereby these parts are protected.

When my improved brake mechanism is

applied to a machine having a socket steering mechanism, the finger F can be omitted, as represented in Fig. 16. In this case the brake-rod f' is composed of two parts connected together by a screw-joint, f^3 , and the lower part bears directly upon the brake-lever E. The lower part is prevented from turning by a screw or other projection, f^4 , which is secured to the lower part of the rod f' and extends into the opening in the rear side of the steering-head.

When my improved brake mechanism is applied to a tricycle, the brake bears against the sprocket-wheel in the usual manner, instead of the tire of the driving-wheel, as shown.

H represents a mud-guard which covers the upper rear portion of the steering-wheel A, and is secured with its front end to the under side of the lug d^2 on the steering-post a' , and with its lower or rear end to the reach C by means of a spiral spring, h . By this construction the lower end of the guard is secured without the usual brace running to the hub of the front wheel. This mode of fastening the mud-guard tends to keep the steering-wheel in line. The mud-guard is preferably constructed of spring-steel or other flexible material, which permits the steering-wheel to be deflected from a straight course by the application of a slight pressure to the handle-bars. A jointed non-elastic coupling, h' , may be substituted for the spring h , and answers the purpose in a measure by twisting the mud-guard. A rigid mud-guard may be used in connection with a spring-fastening between the lower end of the mud-guard and the reach; but these constructions are less desirable than the construction first described.

The sleeve c , which connects the rear end of the reach C to the front ends of the rear fork-arms, C', is fitted into these parts, which are made tubular, and is secured to the same by brazing, so as to rigidly connect these parts together. The sleeve c and adjacent lower portion of the reach C are slotted lengthwise to permit of the insertion of the brake-lever E into the reach C.

I represents the horizontal arm upon which the saddle Y is supported.

J represents a bifurcated brace which extends downwardly and rearwardly from the rear end of the saddle-arm I, and is pivoted with its lower ends to the rear portions of the fork-arms C' by horizontal bolts j .

K represents a curved brace connected with its upper end to the upper end of the bifurcated brace J, and extending downwardly from the latter in front of the driving-wheel A' toward the front end of the fork C'. The upper portion of the brace K is made hollow and crescent-shaped in cross-section, as represented in Fig. 10, and acts as a mud-guard to the driving-wheel.

The brace K is curved concentric with the driving-wheel A', or nearly so, and is open at its lower end, while its upper end is brazed or otherwise firmly secured to the brace J.

L represents a curved bar which is inserted with its upper portion in the lower portion of the brace K. This bar is made rectangular in cross-section, and the lower portion, K' , of brace K is bent or shaped correspondingly, as represented in Fig. 11, to hold the bar L firmly in position against lateral movement, while permitting the bar to be moved lengthwise in the brace K in the direction of its curvature.

The bar L is provided with a series of radial holes, l , through which are passed fastening-bolts l' , whereby the bar is secured in the brace K, as represented in Figs. 1 and 11.

m represents a ratchet-bar secured to the lower front portion of the brace K, preferably by the same bolts, l' , which secure the bar L to the brace.

M represents a pawl which is pivoted to the upper side of the sleeve c , and engages with its upper end against the rack-bar m , so as to support the brace K, the saddle, and the rider seated on the same.

The pawl M is provided with a forwardly-projecting tail-piece, m' , which carries a spring, m^2 . The latter bears against the upper side of the sleeve c and holds the pawl in engagement with the ratchet-bar m .

n represents the crank-shaft, which passes through a bearing, N, attached to the lower end of the curved bar L.

n' represents the cranks secured to the ends of the shaft n , and provided with pedals of any suitable construction.

o o^2 represent two sprocket-wheels secured to the shaft n on opposite sides of the bearing N, and o^4 represents a drive-chain which transmits motion from the crank-shaft to the driving-wheel A' .

The bearing N consists of two tubular portions, p p' . The portion p is provided with two arms, p^2 , which bear against opposite sides of the bar L, and are attached thereto by two horizontal bolts, p^3 p^4 . The upper bolt, p^3 , passes through a hole in the arm L, as represented in Figs. 1 and 2, and the lower bolt, p^4 , passes through a slot, p^5 , which is curved concentric with the bolt p^3 , as shown in Fig. 6, so that upon loosening the bolt p^4 the bearing N can be adjusted forwardly or backwardly by swinging it upon the bolt p^3 , as may be necessary in order to tighten the chain. The part p' of the bearing is screwed into the part p , as represented in Fig. 2, and is further held in place against accidental displacement by a clamp, p^6 , formed on the part p and embracing the part p' , as represented in Fig. 6. Each of the wheels o o^2 is provided on the inner side of its hub with a cone, p^7 , and a row of balls, p^8 , which is interposed between the cone and the adjacent enlarged end of the bearing. The wear is taken up by unscrewing the part p' from the part p when necessary. This construction of the bearing permits both sides to be adjusted at once, and avoids injury to the bearing by bending the fork or frame, and renders the bearing light and simple in construction.

By raising and lowering the bar L in the brace K by means of the series of holes l the distance from the seat to the pedals can be adjusted to adjust the machine to the size of the rider. The front side of the brace K is provided with a series of holes corresponding with the holes l in the bar L, so that by removing the fastening-screws l' the ratchet-bar m can be raised and lowered on the brace K. By depressing the lower arm, m' , of the pawl M the latter is disengaged from the ratchet-bar m , which allows the brace K to drop and lowers the seat. This throws the saddle forward and the pedals slightly backward and enables the rider to retain a vertical action while ascending a hill. The fork-arms C' are connected by a horizontal cross-bar, g , located between the bar L and the driving-wheel A' , and against which the bar L rests, whereby the bar is prevented from springing and pressing against the tire of the rear wheel. By pressing forwardly on the handles or the reach with the foot the saddle and driving-gear are easily raised to the desired position for riding on a level road, or still higher, if desired, for riding on descending ground. The telescopic attachment of the driving-gear to the saddle-supporting brace K permits the distance between the saddle and the pedals to be increased or reduced at will, and the ratchet-bar m and supporting-pawl M permit the saddle and driving-gear to be raised and lowered simultaneously.

The sprocket-wheels o and o^2 on the crank-shaft are made of different diameters, and the sprocket-wheels o' and o^3 of the driving-wheel A' are also made of different diameters. In order to obtain the best results, each of the four sprocket-wheels is made of different diameter from all the others. The driving-wheel turns upon a fixed axle, and the latter is secured in either one of two recesses, r r' , formed in the under side of the rear forks, C' , at the rear ends thereof. The space between the two recesses r r' is equal to the difference in the diameters of the sprocket-wheels o' and o^3 . The axle of the driving-wheel is secured in the recesses of the rear forks, C' , by screws, r^2 , applied to both ends of the axle. This construction enables the rider to quickly disconnect the rear wheel by loosening the two nuts at the ends of the axle. The crank-shaft bearing N may also be disconnected from its support L by removing the bolts p^3 and p^4 .

The sprocket-wheel o is provided with fifteen sprockets, the wheel o^2 with eleven sprockets, the wheel o' with twelve sprockets, and the wheel o^3 with nine sprockets. When the driving-chain o^4 is applied to the wheels o and o' , as represented in Figs. 1 and 3, the machine is geared in the proportion of fifteen to twelve. If a higher-gear is desired, the rear wheel is quickly detached and reversed in the fork, so as to bring the wheel o^3 in line with the wheel o , when the machine will be geared in the proportion of fifteen to nine. In this case the axle of the rear wheel is

secured in the rear recess, *r*, of the fork C', to avoid the necessity of adjusting the drive-chain. When a lower gear is desired, the crank-shaft bearing is detached from its support L and reversed and the wheels *o*² and *o*¹ are geared together, when the machine will be geared in the proportion of eleven to twelve. A slightly-lower gear may be had by connecting the wheels *o*² and *o*³, when the machine will be geared in the proportion of eleven to nine. This may be done either by reversing both sides of the sprocket-wheels or by detaching the chain and placing it on the other side of the machine. If the chain is changed from one of the crank-wheels to the other, it must be readjusted by means of the movable bearing N. It is obvious that all these four sprocket-wheels may be changed by reversing either the driving-wheel or the crank-shaft and changing the chain from one side of the machine to the other without making both pairs of sprocket-wheels reversible. It is also obvious that the number of sprockets on the wheels may be varied to produce higher or lower gears, or to produce one level or equal gear and three speed or power gears, as may be desired. It is also obvious that a two-speed gear is easily made by omitting one of the sprocket-wheels from the hub of the driving-wheel or from the crank-shaft.

I am aware that velocipedes have been used with two pairs of sprocket-wheels and two chains, with a clutch for releasing one pair of wheels from the shaft and coupling the other pair, and this I do not claim.

My improved construction avoids the extra friction of clutches and the weight and expense of the extra chain-and-clutch mechanism, and obtains four different speeds instead of two. Although my improved gearing is not capable of being quickly changed to meet sudden changes in the surface of the road, it may be changed in very little time by dismounting, and is especially desirable for adjusting the speed of the machine to the general average condition of the roads in a certain section of the country, or to the same roads at different seasons of the year. It also enables tourists to change to a slower and easier gear toward the close of a long run, and enables the learner to use a low gear at first and gradually increase the gear as he becomes more proficient.

I claim as my invention—

1. The combination, with a hollow steering-post, of a handle-bar provided with a hollow shank arranged in the steering-post, a brake-hand-lever pivoted to the handle-bar, and a brake-rod arranged in the hollow shank and steering-post, substantially as set forth.

2. The combination, with a hollow steering-post, of a handle-bar provided with a hollow shank arranged in the steering-post and an adjusting-rod arranged in the hollow shank of the handle-bar, whereby the latter can be raised and lowered, substantially as set forth.

3. The combination, with the steering-wheel and its frame and the driving-wheel, of a

reach connecting the driving-wheel with the steering-frame by steering-centers in rear of the steering-post, a brake-lever attached to the reach, a brake-actuating mechanism attached to the steering-frame, and a pivot connecting the actuating mechanism and the brake-lever in line with the steering-centers, substantially as set forth.

4. In a velocipede, the combination, with the hollow reach, of a brake-lever pivoted to the reach and having its upper actuating-arm extending lengthwise through the hollow reach and its lower arm provided with a brake-spoon and projecting from the reach, substantially as set forth.

5. The combination, with the front steering-wheel and its frame and the driving-wheel, of a hollow connecting-reach and a brake adapted to check the rear wheel and having the front arm of its lever arranged in the hollow reach, substantially as set forth.

6. The combination, with the front steering-wheel and its frame and the rear driving wheel or wheels, of a hollow connecting-reach, C, provided at its front end with a hollow head, D, a brake-lever, E, pivoted to the reach and having its front arm arranged within the same, and a retracting-spring, *g*², applied to the brake-lever within the head D, substantially as set forth.

7. The combination, with the front steering-wheel and its frame and the rear driving wheel or wheels, of a hollow connecting-reach, C, provided at its front end with a hollow head, D, a brake-lever, E, pivoted to the reach and having its front arm arranged within the same, and an actuating-finger, F, pivoted to the brake-lever within the head D, substantially as set forth.

8. The combination, with the front steering-wheel and its fork, provided with a hollow steering-post, *a*¹, and the rear driving wheel or wheels, of a hollow connecting-reach, C, provided at its front end with a hollow head, D, a brake-lever, E, pivoted to the reach and having its front arm arranged within the same, an actuating-finger, F, a rod, *f*¹, attached to said finger, and a hand-lever, G, connected with the rod *f*¹, substantially as set forth.

9. The combination, with the front steering-wheel and its frame and the rear driving wheel or wheels, of a connecting-reach and an elastic mud-guard attached to the steering-frame and the reach, whereby the wheels are held in line, substantially as set forth.

10. The combination, with the front steering-wheel and its frame and the rear driving wheel or wheels, of a connecting-reach, a mud-guard, and a spring whereby one end of the mud-guard is attached to the reach, substantially as set forth.

11. The combination, with the front steering-wheel and its frame and the rear driving wheel or wheels, of a connecting-reach, an elastic mud-guard rigidly secured with its front end to the steering-frame, and a yielding connection whereby the rear end of the mud-

guard is attached to the reach, substantially as set forth.

12. The combination, with the main frame connecting the steering-wheel and driving wheel or wheels, of an auxiliary frame made vertically adjustable on the main frame, a saddle supported on the auxiliary frame, and a driving-gear made adjustable on the auxiliary frame toward and from the saddle, substantially as set forth.

13. The combination, with the wheel A, driving-wheel A', reach C, and rear fork, C', of the bifurcated brace J, pivoted to the rear fork, the brace K, secured with its upper end to the brace J and provided with a ratchet-bar, m, a pawl, M, attached to the reach and engaging with said ratchet-bar, a bar, L, adjustably attached to the brace K, and a driving-gear supported by the bar L, substantially as set forth.

14. The combination, with the driving-wheel A' and rear fork, C', provided with a cross-piece, q, in front of the driving-wheel, of the bar L, supporting the driving-gear and resting against the cross-bar q, substantially as set forth.

15. The combination, with the tubular brace K, of the bar L, provided with a series of holes, l, fastening-bolts l', whereby the bar L is adjustably attached to the brace K, and a driving-gear supported by the bar L, substantially as set forth.

16. The combination, with the steering and driving wheels and the connecting-frame, of a tubular brace, K, supporting the saddle, and a bar, L, supporting the driving-gear and held adjustably in the brace K, substantially as set forth.

17. The combination, with the wheel A' and a saddle, I', of a hollow supporting-brace, K, of crescent-shaped cross-section, acting as a mud-guard to the wheel, substantially as set forth.

18. The combination, with the crank-shaft n and sprocket-wheels o o^2 , provided with cones p^2 , of the tubular bearing N, composed of two tubular parts, p p' , secured together by an external and an internal screw-thread, substantially as set forth.

19. The combination, with a driving-wheel adapted to be reversed in the frame and provided with two sprocket-wheels of different diameters, of a crank-shaft provided with a sprocket-wheel and a single drive-chain adapted to connect the crank-shaft with either of the sprocket-wheels of the drive-wheel, substantially as set forth.

20. The combination, with a driving-wheel adapted to be reversed in its frame and provided with a sprocket-wheel, of a crank-shaft, two sprocket-wheels of different diameters rigidly secured thereto, and a single drive-chain whereby the driving-wheel can be connected with either sprocket-wheel on the crank-shaft, substantially as set forth.

21. The combination, with the driving-wheel provided with a sprocket-wheel, of a crank-shaft provided with two sprocket-wheels of different diameters and made reversible, whereby either of said two sprocket-wheels can be connected with that of the driving-wheel by a single chain, substantially as set forth.

22. The combination, with a driving-wheel, A', provided with two sprocket-wheels, o' o^3 , of different diameters, of a crank-shaft, two sprocket-wheels, o o^2 , of different diameters, rigidly secured to the crank-shaft, and a single drive-chain, o^4 , substantially as set forth.

23. In a velocipede, the combination, with a wheel, of a fork or frame having two recesses or seats, r r' , in either of which the axle of the wheel can be secured, substantially as set forth.

EMMIT G. LATTA.

Witnesses:

JNO. J. BONNER,
OSCAR SCHAUB.