

(No Model.)

4 Sheets—Sheet 1.

E. G. LATTA.  
VELOCIPÈDE.

No. 440,897.

Patented Nov. 18, 1890.

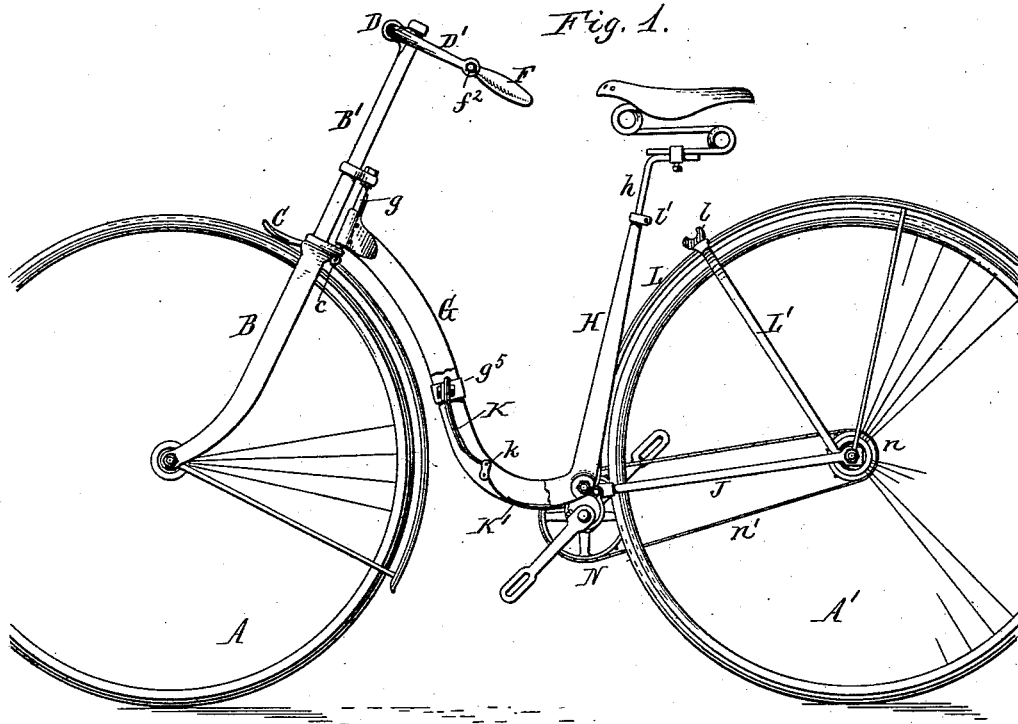
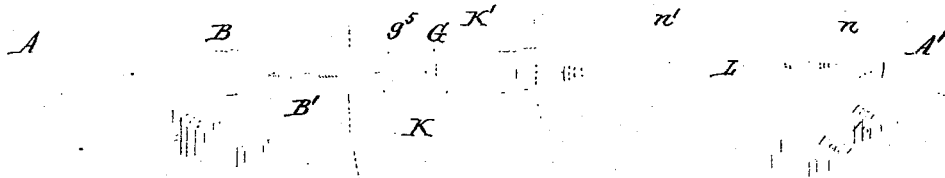

Fig. 2.



Witnesses:

Chas. Buchheit  
Emil J. Neuhart

E. G. Latta Inventor.  
By Wilhelm Hornum  
Attorneys.

(No Model.)

4 Sheets—Sheet 2.

E. G. LATTA.  
VELOCIPEDE.

No. 440,897.

Patented Nov. 18, 1890.

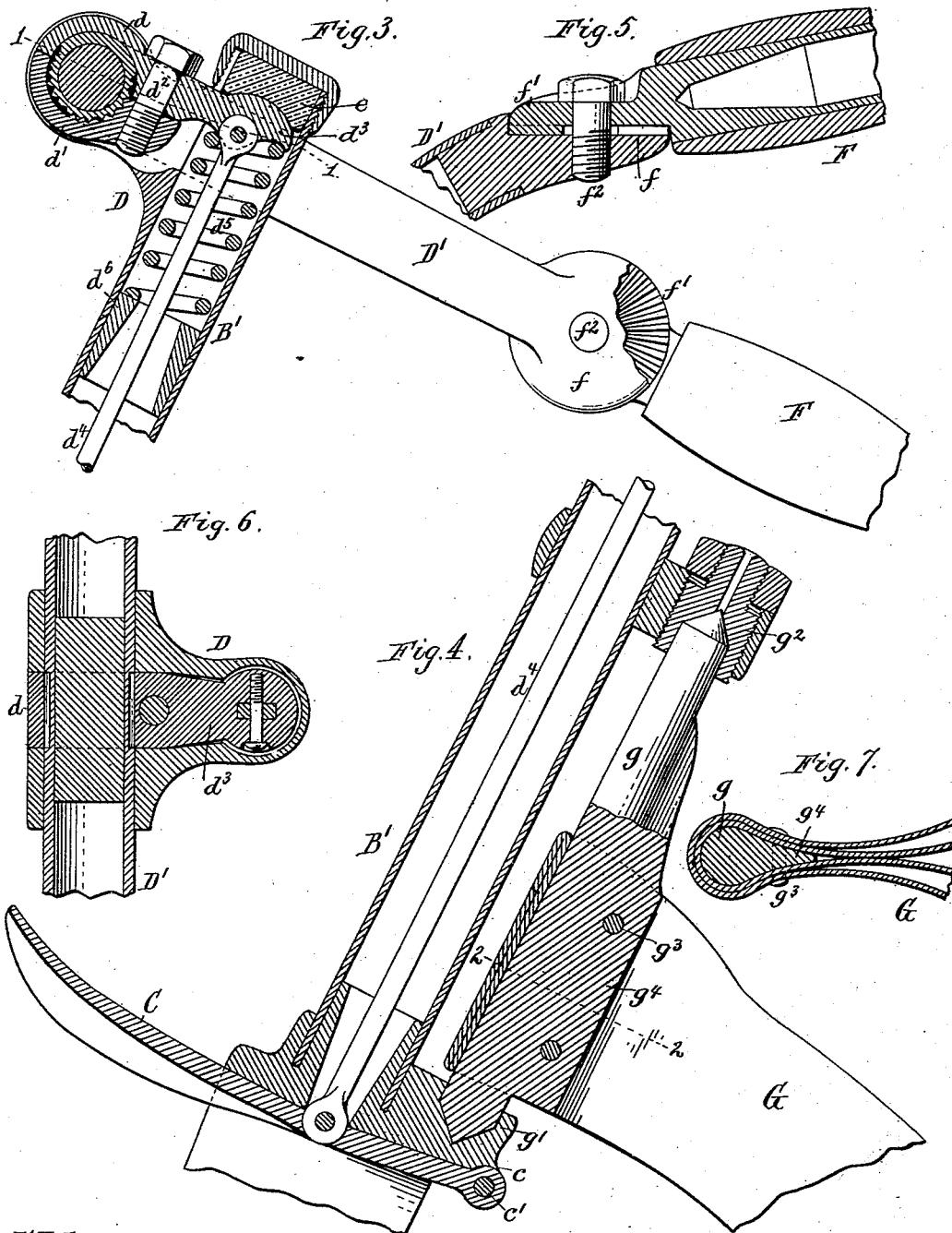

Witnesses:

Chas. Buchheit  
Emil J. Neuhart

E. G. Latta Inventor.

By Wilhelm Stumm  
Attorneys.

E. G. LATTA.  
VELOCIPÈDE.

No. 440,897.

Patented Nov. 18, 1890.

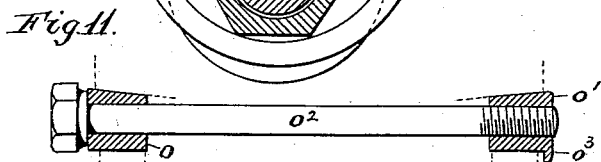
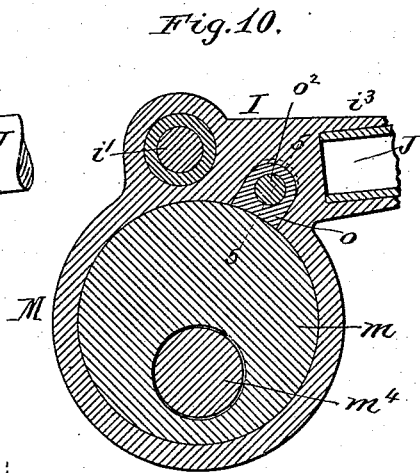
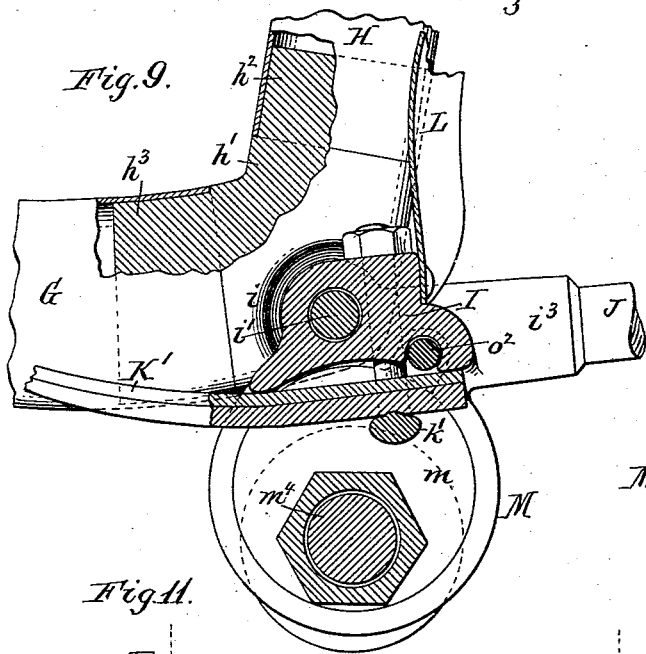
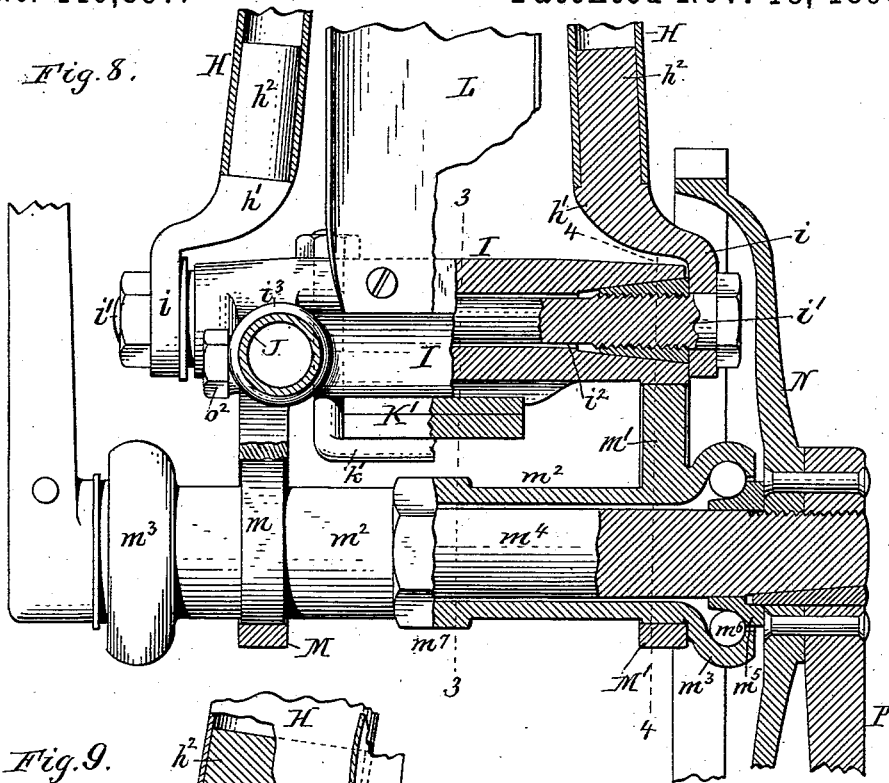

Witnesses:  
*Chas. Buchheit.*  
*Emily Neuhart.*

*E. G. Latta* Inventor.  
 By *Wilhelm Brunnert*  
 Attorneys.

(No Model.)

4 Sheets—Sheet 4.

E. G. LATTA.  
VELOCIPÈDE.

No. 440,897.

Patented Nov. 18, 1890.

Fig. 12.

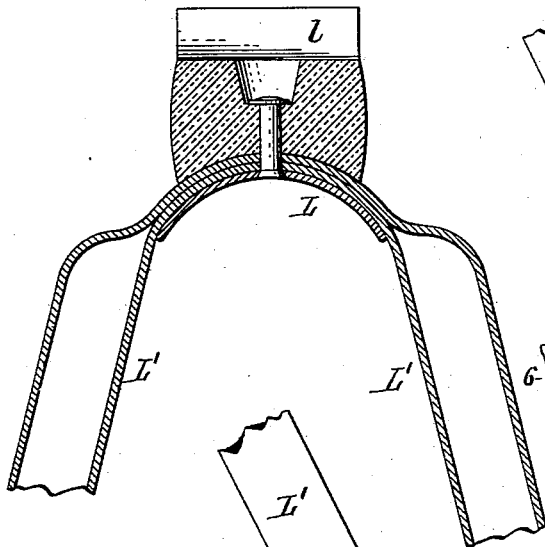

Fig. 13.

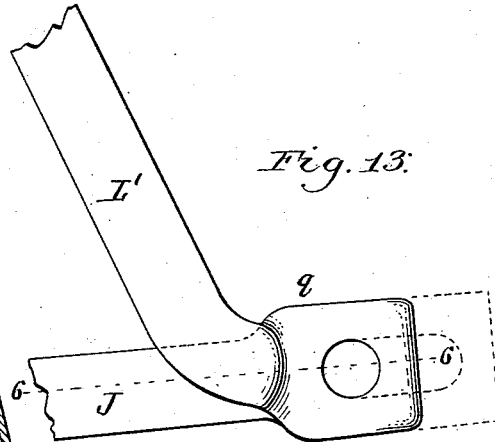

Fig. 14.

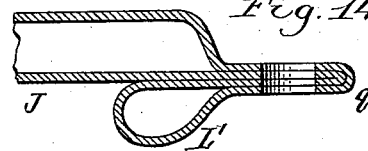

Fig. 15.

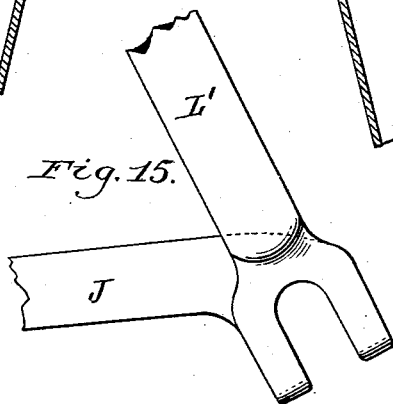

Fig. 18.

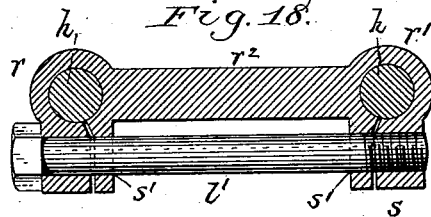

Fig. 16.

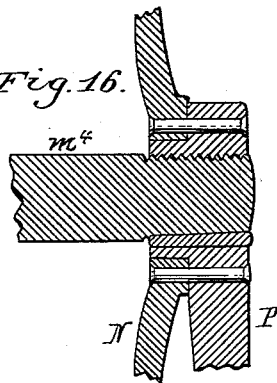

Fig. 17.

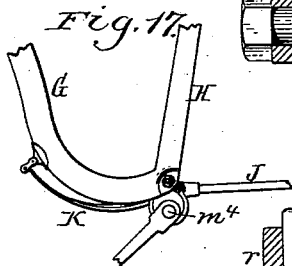
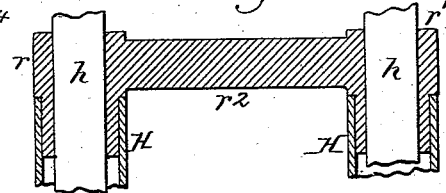

Fig. 19.



Witnesses:

Chas. Buchheit.  
Emil J. Neuhart.

E. G. Latta Inventor.

By Wilhelm Hornet.

Attorneys.

# UNITED STATES PATENT OFFICE.

EMMIT G. LATTA, OF FRIENDSHIP, NEW YORK.

## VELOCIPEDE.

SPECIFICATION forming part of Letters Patent No. 440,897, dated November 18, 1890.

Application filed December 26, 1889. Serial No. 335,059. (No model.)

*To all whom it may concern:*

Be it known that I, EMMIT G. LATTA, a citizen of the United States, residing at Friendship, in the county of Allegany and State of New York, have invented new and useful Improvements in Velocipedes, of which the following is a specification.

The principal object of my invention is to produce a durable and efficient Safety bicycle which may be used by either sex and which is especially adapted for rough roads.

The invention has the further object to reduce the weight of the machine and lessen its cost of manufacture.

In the accompanying drawings, consisting of four sheets, Figure 1 is a side elevation of my improved velocipede with the pedals omitted and a part of the reach broken away. Fig. 2 is a top plan view thereof with the saddle and saddle-pillar removed. Fig. 3 is a sectional elevation of the upper portion of the steering-post and connecting parts. Fig. 4 is a sectional elevation of the lower part of the steering-post and connecting parts. Fig. 5 is a fragmentary longitudinal section of the handle-bar and one of the handles, showing the manner of adjustably securing these parts together. Fig. 6 is a cross-section in line 1 1, Fig. 3. Fig. 7 is a longitudinal section of the perch or reach in line 2 2, Fig. 4. Fig. 8 is a sectional elevation of the central part of the main frame and driving-gear. Fig. 9 is a vertical cross-section in line 3 3, Fig. 8, and Fig. 10 is a similar section in line 4 4, Fig. 8. Fig. 11 is a longitudinal section in line 5 5, Fig. 10, showing the wedges for clamping the eccentric-bearings of the crank-shaft and the adjusting-bolt for operating the wedges. Fig. 12 is a fragmentary longitudinal section of the upper fork or frame of the rear wheel. Fig. 13 is a side elevation of the rear portion of the rear-wheel frame. Fig. 14 is a longitudinal section in line 6 6, Fig. 13. Fig. 15 is a modification of the rear-wheel frame. Fig. 16 is a fragmentary longitudinal section, showing a modified construction of the sprocket-wheel and crank. Fig. 17 is a modified construction of the main frame and the spring connecting the parts of the frame. Fig. 18 is a cross-section of the clamp at the upper end of the tubes supporting the saddle-pillars.

Fig. 19 is a vertical section of said clamp and connecting parts.

Like letters of reference refer to like parts in the several figures.

A represents the front wheel; A', the rear wheel; B, the fork of the front wheel, and B' the tubular steering-post secured thereto.

C represents the brake-spoon arranged at the upper end of the front fork and pivoted at its rear end to a lug or rearward extension c, formed at the upper end of the fork, by a horizontal bolt c'.

D is the handle-bar lug arranged at the upper end of the steering-post and provided with a circular opening, in which the central portion of the handle-bar D' is journaled and is free to turn to a limited extent. The upper part of the steering-post with the handle-bar lug is preferably brazed to the remaining portion of the post; but it may be made integral therewith, if desired. The central portion of the handle-bar lug is recessed or cut away, as shown in Fig. 6.

d d' represent a two-part clamp embracing the central portion of the handle-bar and arranged in the recess of the handle-bar lug. The parts of this clamp are firmly secured together in rear of the handle-bar by a clamping-bolt d<sup>2</sup>, and the contiguous faces of the handle-bar and the lower part d' of the clamp are preferably provided with interlocking teeth or ribs to effectually prevent the clamp from slipping on the handle-bar. The upper part d of the clamp is formed with a rearward extension or arm d<sup>3</sup>, which projects with its enlarged end into the tubular steering-post through an upright slot formed in the front side of the post.

d<sup>4</sup> represents the brake-rod arranged within the tubular steering-post and which connects the brake-spoon with the rearwardly-projecting arm of the clamp d d'.

d<sup>5</sup> is a spiral spring surrounding the connecting-rod d<sup>4</sup> and interposed between the arm of the clamp and an annular shoulder or offset d<sup>6</sup>, arranged within the steering-post. This spring tends to hold the handle-bar and the brake-spoon in an elevated position.

e represents an elastic block or cushion of rubber arranged within the upper portion of the tubular steering-post above the arm of

the clamp  $d'$ , and against which the latter bears when the handle-bars are elevated. The cushion is retained in place by a screw-cap applied to the threaded upper end of the steering-post.

The end portions of the handle-bar are bent backwardly, as represented in Figs. 1 and 2, and terminate in flattened circular heads  $f$ .

F represents the handles, which are provided at their front ends with similar heads  $f'$ , which are adjustably secured to the heads of the handle-bar by transverse bolts  $f^2$ , passing through central openings in the heads, as represented in Figs. 3 and 5. The contiguous faces of these heads are preferably provided with interlocking radial ribs or teeth to freely hold the handle against turning on the handle-bar. The handle-bar is adjusted to the proper height to suit the rider by loosening the clamping-bolt  $d^2$  and turning the bar in the clamp  $d'$  and again tightening said bolt after adjusting the handles. When the front wheel strikes an obstruction, the spiral spring  $d^3$  yields under the weight of the rider's arms and the handles descend slightly, and as soon as the force of the shock is spent the springs return the handles to their former elevated position. This action greatly relieves the rider's hands from the tiresome effects produced by the vibrations of the machine. This movement of the handle-bar also causes the brake rod and spoon to descend, but does not cause the spoon to come in contact with the front wheel except in case of a violent shock.

The rubber cushion  $e$  prevents rattling of the parts and limits the upward movement of the handles by the clamping-arm  $d^3$  striking the cushion. The tension of the spiral spring and rubber cushion may be increased by inserting one or more washers under or above these parts.

In applying the brake the rider pushes the handles downward sufficiently to press the brake against the wheel and exerts such additional pressure as may be necessary to check or stop the machine.

The range of adjustment of the handle-bar is preferably made to correspond to that of the saddle. When the handle-bar is adjusted to the extreme lower limit of its range, the handles, if arranged in line with the end portions of the handle-bar, will point downward instead of slightly upward or nearly horizontal, and if the handle-bar is set at the extreme upper limit of its range the upward inclination of the handles will be too great for the comfort and convenience of the rider. In order to permit the handle-bar to be adjusted to either extremity of its movement and still maintain a comfortable position or inclination of the handles, the latter are adjustably secured to the handle-bars, as before described. Upon loosening the clamping-bolts  $f^2$  the handles may be adjusted to any desired position irrespective of that of the handle-bar, and after the adjustment is ef-

fecting the bolts are again tightened to firmly secure the handles in place. The bolts  $f^2$  are arranged parallel with the central part of the handle-bar, so that the inward or outward angle of the handles remains unchanged.

By my improved construction a separate brake-lever and spring are dispensed with, the handles are capable of a greater variety of adjustment, the steering-post is rendered neater in appearance and stronger in construction, and the steering and brake mechanisms, as a whole, are rendered more reliable than heretofore.

My improved brake mechanism may be used in connection with a brake applied to the rear wheel; but it is especially desirable for a front-wheel brake because greater pressure may be exerted therewith than with an ordinary brake, and because it applies the pressure at a point in rear of and above the steering-centers, thus counteracting the tendency to bend or break the steering spindle or reach—a defect which is found in front-wheel brakes as usually applied to velocipedes of this class.

G represents the reach or perch whereby the forks or frames of the front and rear wheels are connected together, and  $g$  is the steering-spindle arranged at the front end of the perch and journaled with its lower center in a bearing  $g'$ , formed in the extension  $c$  at the upper end of the front fork, and with its upper center in an adjustable bearing  $g^2$ , secured to the steering-post.

The reach G consists of two parts or branches, as represented in Fig. 2, and is composed of a single piece of tubing oval in cross-section and flattened at its central portion. This flattened portion is bent or doubled around the lower portion of the steering-spindle and secured thereto by transverse rivets or bolts  $g^3$ , passing through a rearwardly-projecting longitudinal web  $g^4$ , formed on the spindle and through the adjacent portions of the reach, as represented in Figs. 4 and 7. The reach is also preferably brazed to the spindle and web. From the flattened portion of the reach the branches thereof diverge rearwardly and downwardly and follow the periphery of the front wheel for about one-seventh of its circumference. Thence they extend rearwardly parallel with each other and are connected at their rear ends with the upright tubular posts H H, which support the saddle-pillars  $h$ .

As represented in Fig. 2, the branches of the perch are connected about midway of their ends by a cross-bar  $g^5$ , whereby the parts of the reach stiffen each other. The lower ends of the reach branches are secured to the upright posts H by angle plates or irons  $h'$ , having upright stubs  $h^2$ , seated and brazed in the lower ends of the posts H, and horizontal stubs  $h^3$ , seated in the rear ends of the reach branches, as represented in Figs. 8 and 9.

I represents a transverse head or block ar-

ranged between two depending lugs or ears  $i$ , formed, respectively, on the angle-plates  $h'$ , and  $i'$  is a horizontal bolt secured with its ends in openings in the lugs  $i$  and passing through a horizontal opening  $i^2$ , formed in the head or block I, as represented in Figs. 8 and 9. The head I is provided on its rear side with sockets  $i^3$ , in which the front ends of the lower rear fork J are secured by brazing or otherwise, as represented in Figs. 1, 8, 9, and 10. The head I and bolt  $i'$  thus form a pivotal connection between the front and rear frames of the machine. The lugs  $i$  are arranged as far apart as possible, so as to afford a wide bearing for the pivot-joint between the two parts of the frame.

K represents a flat curved spring attached at its upper end to the cross-bar  $g^3$ , connecting the branches of the reach, and  $K'$  is a similar spring attached at its front end to the lower end of the spring K, preferably by a shackle  $k$ , and at its rear end to the under side of the block or head I by a clip  $k'$  or other suitable means. The springs are arranged below the upper surface of the reach, where they are out of the way, and are preferably placed between the two parts of the reach, so as to be concealed from view. The two springs form a yielding connection between the front and rear frames of the machine, which relieves the rider in case the machine receives a shock by striking an obstruction, but which is at the same time sufficiently stiff to keep the front and rear frames in the proper relative position under ordinary conditions. The under side of the head or block I is recessed or made concave, as shown in Fig. 9, so that the spring may be stiffened and its tension increased by drawing the end portion of the spring into said recess by means of the screw-nuts of the clip  $k'$ . This causes the spring to be nearly straightened and correspondingly limits the range of movement of the joint connecting the two parts of the frame.

In case the machine is to be used by a very heavy rider the tension of the spring can by this means be readily increased.

L represents the mud-guard, and  $L'$  the upper fork of the rear wheel, which extends from the inner portion of the lower fork J outwardly to the mud-guard L. The latter is preferably secured at its lower end to the rear side of the head or block I, as shown.

$l$  represents a rubber block or buffer secured to the outer end of the upper fork  $L'$  and which is adapted to bear against a bolt  $l'$ , connecting the upper end of the upright tubular posts H. When the machine receives a very violent shock, which overcomes the resistance of the springs  $KK'$ , the rubber buffer  $l$  strikes the cross-bolt  $l'$  and limits the farther inward movement of the front and rear wheel frames. The upper spring is arranged in such manner that it has a pulling action nearly in the direction of its length, so that it will yield slightly when either wheel receives a slight shock or jolt. When the machine receives a

violent shock, the spring  $K'$ , which is made somewhat stiffer than the spring K, yields sufficiently to allow the buffer  $l$  to strike the bolt  $l'$ .

In the modified construction represented in Fig. 17 a single perch or reach and saddle-supporting post of the usual form are shown and a single spring, like the spring K, is employed. The shackle at the front end of the spring is in this case attached directly to the under side of the perch. This forms a simple and cheap construction which accomplishes the desired result, but is less desirable than the double or compound spring first described.

$M M'$ , Figs. 8, 9, and 10, represent two depending rings or hangers formed on or secured to the head or block I, and  $m m'$  are adjustable eccentrics arranged in said rings or bearings and which are connected by a tube or sleeve  $m^2$ . The latter is provided at its ends with grooved bearing-boxes  $m^3$ .

$m^4$  is the crank shaft passing through the sleeve  $m^2$  and journaled therein. The crank-shaft is provided with cones  $m^5$ , between which and the grooved bearing-boxes  $m^3$  are interposed balls  $m^6$ . If desired, the sleeve  $m^2$  may be formed with plain bearings for the crank-shaft; but an ordinary single ball-bearing of the construction shown is preferably used.

To enable the eccentrics to be made as small as possible, they are located between the enlarged ends or bearing-boxes of the sleeve  $m^2$ , as shown. In order to permit the parts to be assembled, the eccentric  $m$  is arranged at a sufficient distance from the adjacent bearing-box  $m^3$  to permit the latter to be lowered or moved laterally after passing through the ring M, so as to enable the eccentrics to be inserted in their seats. The tube or sleeve  $m^2$  is provided with a flat-sided collar  $m^7$  for turning it.

N represents the sprocket-wheel secured to one end of the crank-shaft  $m^4$ , and which is connected with the sprocket-wheel  $n$  on the axle of the rear wheel by a chain  $n'$  in the usual manner.

$o o'$  represent wedges arranged in recesses in the upper portions of the rings or bearings M  $M'$  and bearing against the adjacent peripheral portions of the eccentrics  $m m'$ , so as to clamp the latter in the rings and hold them against turning. These wedges are connected together and operated by a horizontal adjusting-bolt  $o^2$ , which passes with its outer smooth portion through a smooth opening in the adjacent wedge  $o$  and engages with its inner threaded end in a threaded opening in the other wedge  $o'$ . Upon turning this adjusting-bolt in one direction the wedges are moved inwardly toward each other and caused to clamp the eccentrics in the rings, while upon turning the bolt in the opposite direction the wedges are released from the eccentrics and the latter are free to turn in their rings or bearings. To adjust the drive-chain the adjusting-screw  $o^2$

is turned in the proper direction to release the wedges  $o$   $o'$ . The eccentrics are then turned by applying a wrench to the collar of the sleeve  $m^2$  until the crank-shaft is shifted forwardly sufficiently to properly adjust and tighten the chain. After the chain is adjusted the eccentrics are again clamped in place by tightening the wedges.

$o^3$  represents a lip or projection formed on the wedge  $o'$ , and which overlaps the outer edge of the eccentric  $m$ , so as to prevent the eccentric from moving outwardly out of its ring. The eccentric is held against movement in the opposite direction by the bearing-box  $m^3$ , resting against the outer side of the ring  $M'$ .

The sprocket-wheel  $N$  is made concave or dished on its inner side, as represented in Fig. 8, and, instead of forming it with a hub of sufficient width to support it, the hub is made just wide enough to form a reliable center bearing, and this narrow hub is secured to the boss of the adjacent crank  $P$  by bolts or rivets or other means. By this construction the boss of the crank may also be made of less than the usual thickness, as it is supported largely by the hub of the sprocket-wheel, thereby reducing the weight of the parts and permitting a closer build. This construction of the crank and sprocket-wheel permits both of these parts to be secured to the crank-shaft within the space usually required for one and allows the bearing-box  $m^3$  to be placed as closely to the crank on the side on which the sprocket-wheel is arranged as on the opposite side. It also permits the adjacent lug  $i$  to be located within the sprocket-wheel, thereby increasing the distance between the bearings of the pivot-bolt  $i'$ , as well as that between the crank-shaft bearings, and enabling both to more effectually resist the side strains to which they are subjected and rendering the machine stronger and more durable.

In the modified construction represented in Fig. 16 the crank-boss is formed on its inner side with a projecting internally-threaded rim or collar  $p$ , which surrounds the axle and fits into the central opening of the sprocket-wheel.

The upper and lower forks  $J$  and  $L'$  of the rear-wheel frame are preferably formed of a single piece of tubing, which is flattened at its central portion and bent or doubled to form the parts of the upper fork  $L'$  on opposite sides of the wheel. This flattened central portion is secured to the mud-guard by a rivet or other fastening, as represented in Fig. 12. The two branches of the tubing on opposite sides of the wheel are again bent or doubled upon themselves at or near their central portions, as shown at  $q$  in Fig. 13, to form the forwardly-extending lower fork  $J$ , and these doubled portions are perforated for the passage of the rear axle. The axle is thus supported by a double thickness of tubing, and the use of separate re-enforcing parts

is avoided. This construction avoids the expense and unreliability of brazing in separate parts at the junction of the different parts and reduces the weight to a slight extent.

When my improvement is embodied in a rigid frame of any kind, I prefer to form the doubled portion at the junction of the upper and lower forks of the rear frame, as represented in Fig. 15, the doubled portion being inclined and provided with an inclined recess or seat for the axle, as shown.

If a very cheap drive-chain adjustment is desired, the lug formed at the junction of the fork by doubling the tubing may be provided with a horizontal slot or elongated opening, as shown by dotted lines in Fig. 13, in which slot the axle is clamped, and in which it may be adjusted to tighten the chain.

My improvement in the rear-wheel frame is equally desirable for frames constructed of rods having a crescent-shaped cross-section and for frames of other cross-section. It is also desirable in frames composed of round rods and semi-hollow strips.

Referring to Figs. 18 and 19,  $r$   $r'$  represent two stubs secured in the upper ends of the saddle-supporting tubes  $H$  by brazing or otherwise and connected together by a cross-bar  $r^2$ . These stubs are provided with vertical openings, in which the saddle-pillars  $h$   $h$  are arranged. The stubs are each provided with a lug  $s$ , which is split vertically from its outer edge to the opening in the stub. The split lugs  $s$  are each provided with a horizontal opening  $s'$  and are connected by the bolt  $l'$ , which passes through the openings in the lugs. The opening  $s'$  in one of the lugs is provided with a screw-thread, and the end of the bolt  $l'$  passing through this lug is screw-threaded to engage with the screw-threaded opening. Upon tightening this screw-bolt the parts of the split lugs and stubs are drawn together and caused to tightly clamp the saddle-pillars. By this construction both saddle-pillars are released and clamped simultaneously, rendering it as easy and convenient to adjust the double saddle-pillar as a single pillar.

I claim as my invention—

1. The combination, with the steering-post and the rearwardly-bent handle-bar attached to the same and capable of rotary adjustment thereon, of handles adjustably secured to the rearwardly-bent ends of the handle-bar and capable of vertical adjustment on the handle-bar, substantially as set forth.

2. The combination, with the steering-head, of a yielding handle-bar pivoted thereto, having backwardly-bent ends and capable of rotary adjustment, whereby the elevation of its bent end portions may be adjusted to suit the rider, substantially as set forth.

3. The combination, with the steering-post and a handle-bar having rearwardly-bent ends and capable of rotary adjustment on the steering-post, of handles capable of vertical adjustment on the rearwardly-bent ends of the

handle-bar and transverse bolts connecting the front ends of the handles to the handle-bar and arranged parallel with the transverse central portion of the handle-bar, whereby the handles are rendered vertically adjustable without changing their angle laterally, substantially as set forth.

4. The combination, with the steering-head and the handle-bar pivoted thereto and having backwardly-bent ends, of an arm or lever adjustably attached to the handle-bar and a spring bearing against said arm and resisting the rotary movement of the handle-bar, substantially as set forth.

5. The combination, with the steering-post and a rearwardly-bent handle-bar pivoted thereto, having handles made vertically adjustable on the rearwardly-bent ends of the handle-bar, of an arm or lever attached to the handle-bar and a spring arranged in the steering-head and bearing directly against the arm or lever of the handle-bar, substantially as set forth.

6. The combination, with the hollow steering-post and the pivoted handle-bar having an arm or lever projecting into the hollow post, of a spring which resists the rotary movement of the handle-bar and an elastic cushion arranged in the hollow steering-post above the arm or lever of the handle-bar and receiving the impact of said arm, substantially as set forth.

7. The combination, with the steering-post and the handle-bar pivoted thereto and having backwardly-bent ends, of a clamp adjustably secured to the handle-bar and having an arm projecting into the steering-post and a spring arranged within the steering-post and bearing against the arm of the handle-bar, substantially as set forth.

8. The combination, with the steering-post and the handle-bar pivoted thereto and having backwardly-bent ends, of a clamp adjustably secured to the handle-bar and having an arm projecting into the steering-post, a spring arranged within the steering-post and bearing against the arm of the handle-bar, and an elastic cushion arranged in the steering-head above the arm of the handle-bar and against which the arm bears when the ends of the handle-bar are elevated, substantially as set forth.

9. The combination, with the steering-spindle and the frame of the rear wheel, of a double reach composed of a single piece of tubing doubled or bent at its center and attached at its bent front portion to the steering-pivot and having its end portions extending rearwardly side by side on opposite sides of the front wheel and secured to the frame of the rear wheel, substantially as set forth.

10. The combination, with the steering-pivot or spindle provided on its rear side with a projecting web, of a reach composed of two tubes arranged side by side and attached at their front ends to the web of the steering-spindle, substantially as set forth.

11. The combination, with the frame of the rear wheel and the frame of the front wheel, having a steering spindle or pivot, of a double reach connected at its upper front end to the spindle and at its rear end to the frame of the rear wheel, upright saddle-supporting posts, and couplings connecting said posts to the rear ends of the reach, substantially as set forth.

12. The combination, with the frames of the front and rear wheels and a transverse pivot or bolt connecting the same, of a reach composed of two tubes rigidly connected together at their front ends and also at their central portions and having their lower ends attached to said pivot-bolt, substantially as set forth.

13. The combination, with the frames of the front and rear wheels, connected together by a joint or pivot, of a spring attached to the front frame and a spring attached to the rear frame and connected to the spring of the front frame, substantially as set forth.

14. The combination, with the front steering-wheel and rear driving-wheel, of a frame supporting the driving-wheel and provided with a spring, a frame jointed to the rear frame and supporting the front wheel, a handle-bar and saddle-support, and a spring attached to said front frame and attached to the spring of the rear frame, said springs acting in conjunction to form an elastic connection between the front and rear frames, substantially as set forth.

15. The combination, with the frames of the front and rear wheels, of a reach depressed at its rear portion and pivoted to the frame of the rear wheel, and a spring rigidly secured to the rear-wheel frame, extending forwardly under the depressed portion of the reach and attached at its front end thereto, substantially as set forth.

16. The combination, with the jointed front and rear wheel frames, of a flat spring rigidly secured to the rear frame and pivotally connected to the front frame, substantially as set forth.

17. The combination, with the jointed front and rear wheel frames, of a flat spring rigidly secured to the rear frame and a shackle connecting the front end of the spring to the frame of the front wheel, substantially as set forth.

18. The combination, with the frame of the front wheel and the frame of the rear wheel, jointed thereto and provided with a concave seat, of a flat spring pivotally connected at its front end to the front-wheel frame and a clip whereby the rear end of the spring is secured against the concave seat of the rear frame, substantially as set forth.

19. The combination, with the frame of a velocipede, having a double tubular saddle-supporting post provided with split lugs, of a double saddle-pillar arranged in the double supporting-post and a clamping screw or bolt passing through said lugs, whereby both parts of the double saddle-pillar are clamped and

released simultaneously, substantially as set forth.

20. The combination, with the frame of a velocipede, having a double saddle-supporting post, of perforated stubs arranged in said posts and provided with split lugs, a cross-bar connecting said stubs, a double saddle-pillar arranged in the perforated stubs, and a clamping bolt or screw passing through said lugs, substantially as set forth.

21. The combination, with the supporting-frame of a velocipede, provided with hangers or supports, of a journal-box provided at or near its ends with eccentric-collars arranged in the hangers of the frame, whereby the journal-box is supported near its opposite ends, and a crank-shaft supported in said journal-box, substantially as set forth.

22. The combination, with the supporting-frame of a velocipede, provided with hangers or supports, of a journal-box provided on opposite sides of its center near its ends with eccentric-collars arranged in the hangers of the frame, whereby the journal-box is supported near its opposite ends, a crank-shaft supported in said journal-box, and a clamping device whereby the eccentric-collars are locked against turning in their hangers or supports, substantially as set forth.

23. The combination, with the supporting-frame of a velocipede, provided with hangers or supports, of a journal-box or sleeve provided at or near opposite ends with eccentrics arranged in the hangers or supports of the frame, a crank-shaft supported in said journal-box, wedges arranged in said hangers and bearing against the eccentrics, and a clamping screw or bolt connecting said wedges,

whereby the same are operated simultaneously, substantially as set forth.

24. The combination, with the main frame of a velocipede, of a fork or frame arranged on one side of the wheel and consisting of a single tube or rod doubled or folded upon itself at its central portion, said doubled portion being perforated for the passage of the wheel-axle and having its branches arranged at an angle to each other and secured at their ends to different portions of the main frame, substantially as set forth.

25. The combination, with the front frame, the rear wheel, and the mud-guard or other part arranged over the upper portion of the wheel, of a fork or frame consisting of a single tube or rod bent or doubled at its central portion and secured at said doubled portion to the mud-guard, the branches of the tube extending from the mud-guard to the axle of the wheel and being again doubled upon themselves at the axle and extended forwardly to the main frame, substantially as set forth.

26. The combination, with the jointed frames of the front and rear wheels, of a pivot-bolt attached to the front frame, a spring connecting the front and rear frames, a block or head connected to the rear frame arranged upon said pivot-bolt and provided with a seat for the rear end of the connecting spring, and a crank-shaft supported in said block or head, substantially as set forth.

Witness my hand this 20th day of December, 1889.

EMMIT G. LATTA.

Witnesses:

FRED H. RICE,  
C. J. RICE.